

PAPER • OPEN ACCESS

## Study of influences in CEM's new transfer standard for torque measurements in the MN•m range

To cite this article: R M Lorente-Pedreille *et al* 2018 *J. Phys.: Conf. Ser.* **1065** 042039

View the [article online](#) for updates and enhancements.



**IOP | ebooks™**

Bringing you innovative digital publishing with leading voices to create your essential collection of books in STEM research.

Start exploring the collection - download the first chapter of every title for free.

## Study of influences in CEM's new transfer standard for torque measurements in the MN•m range

R M Lorente-Pedreille<sup>1,3</sup>, N Medina-Martín<sup>1</sup>, M A Sáenz-Nuño<sup>2</sup>, M A Sebastián-Pérez<sup>3</sup>

<sup>1</sup> Centro Español de Metrología (CEM), Spain,

<sup>2</sup> ETSI ICAI (Universidad Pontificia Comillas), Spain,

<sup>3</sup> ETS Ingenieros Industriales (UNED), Spain,

Email: rlorente31@alumno.uned.es; mnmedina@cem.minetur.es;  
msaenz@icai.comillas.edu; msebastian@ind.uned.es

**Abstract.** This paper presents the new development of a transfer standard for torque measurements. It will also go in detail with the influence quantities for the functional performance of the system. The results of this research are based on the new EMPIR project (14IND14: "Torque measurement in the MN•m range" [1]) which aims to provide traceability in the MN•m range for nacelle test benches. This new development is based on the working principle of force-lever systems, where torque is measured by means of force measurements. For its application in nacelle test benches, whose normal operation occurs under rotation, certain influences need to be considered. This paper describes what influences may affect this new system, its estimation and how the design has been improved in order to minimize their effect on torque measurements.

### 1. Introduction

The research, hereinafter described, is part of the EMPIR project 14IND14: "Torque measurement in the MN•m range" in which the CEM is a participant. This project aims to provide traceability in the MNm range, especially for the increasing needs in the wind energy production industry.

According to the European Wind Energy Association, wind energy production is forecasted to dramatically increase, and therefore major technical developments in wind turbine will take place [2].

Nacelle Test Benches are facilities which ensure good wind turbine performance through several analyses, where the most important parameters for diagnosing wind turbines are checked. One of the more important parameters to be checked is torque, as it has a direct impact in final power output.

Unfortunately, despite the relevance of torque, current torque measurements methods have several drawbacks and any of the available approaches measures torque in a direct, traceable way [3]. Furthermore, direct measurements by means of torque transducers are not possible, as there are no calibration facilities widely available for torque transducers working in the operating range of nacelle test benches (MN•m).

The solution proposed by CEM in the EMPIR project is a force-lever system, which is capable of measuring the torque magnitude by using force transducers, mounted on a lever arm of calibrated length. The actual torque value will be calculated multiplying the arm length and the force measured by those force transducers.

## 2. CEM's Force-lever system concept and characteristics

The force lever-system is mounted within the drive chain of a nacelle test bench. All the components of this drive chain are rotating during the measuring process. For this reason, all the components of the lever arm are contained within two flanged ends for its assembly.

The two main components within the system are the lever arm and the force transducers. Both components are in contact and, once the test is started, the force transducers will measure the force of this contact. One of the flanges includes the built-in lever arm, while the other flange contains the components needed for housing the force transducers and its supports (Figure 1).

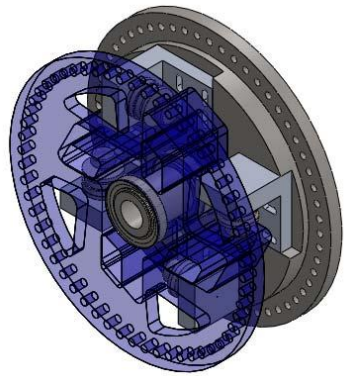

**Figure 1.** CEM' transfer standard

Although the aim of the system is to provide traced torque measurements, other loads appear during the test. In order to accurately reproduce field conditions, a load application system is included in the nacelle test benches within its drive chain. That one generates lateral and axial forces, as well as bending moments. In order to transmit these loads, but minimizing their effect on torque measurements, the force-lever system includes a pair of counter roller bearings. Even including these components, the force-lever system may be affected by several different influence factors.

## 3. FEM analysis for evaluating influences on torque measurements.

The possible influence factors that may affect the final measurement uncertainty have been studied through several FEM analyses. Torque measurements are obtained as the product for the lever arm length and the force load measured by the force transducers. Evaluating possible variations on the measured force or the lever arm length was necessary in order to estimate the final uncertainty.

Several influences were considered and studied. Those ones with a bigger impact on the final measurement which were possible to be studied through FEM analysis were: Additional loads, Centrifugal Force, Gravity and Temperature. The operating conditions data for these influences were provided by nacelle test benches operators based on their experience.

### 3.1. Lever-arm design and influence study

The lever arm has been designed and improved through an iterative process. From the initial design (as described in [4]), several improvements were made in order to minimize the effect of the different contributions. Most of those modifications led to reducing the lever arm weight, and therefore decreasing the gravity effect and the inertia during the tests.

The main parameters to be observed during this iterative process were the maximum von Mises stress, in order to check and ensure that the lever arm stiffness was acceptable, and its associated deformation, which has a direct impact on the total lever arm length and, therefore, in torque measurements.

Once the optimal design was achieved, all the considered influences in the lever arm were studied, separately and combined (Figures 2 and 3)

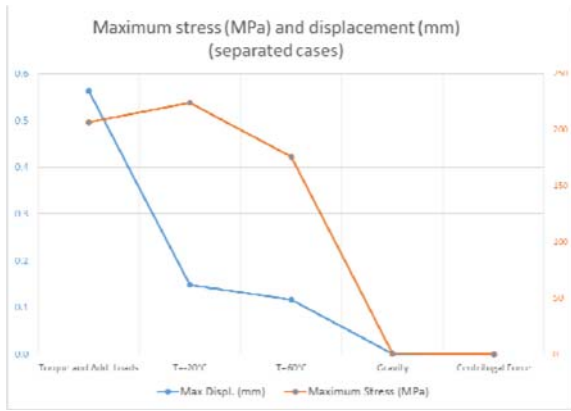

**Figure 2.** Maximum stress (MPa) and displacement (mm) – Separated cases

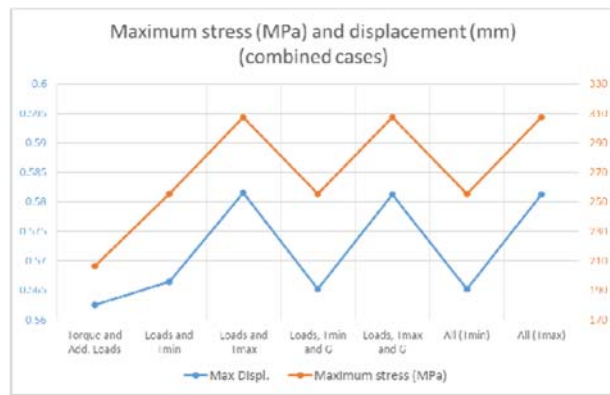

**Figure 3.** Maximum stress (MPa) and displacement (mm) – Combined cases

As shown in the plots, the biggest stress and lever arm length variation are obtained under the main torque load and the additional loads conditions, reaching values of 2.07 MPa (materials allowable maximum stress including 30 % safety factor: 615 MPa). This is completely different from the situation under the other influences, gravity and centrifugal force, which are negligible.

When studied separately, it turns out that low temperatures do also deal with high stresses, although not very significant deformations: only 0.148 mm for the maximum displacement value, while for the torque and additional load influence study 0.563 mm is obtained. However, when studying the different effects combined, the results show that low temperatures, when combined with the applied loads, causes a lower maximum stress and displacement than when applying high temperature values. This is due to the direction of the deformation. Low temperatures produce contraction of the system, while high temperatures and applied loads produce material volumetric expansion. Anyway, respect to the main case, where only nacelle test benches' loads are considered, the rest of the considered influences has a much lower effect on the final lever arm performance.

*3.2. Complete force lever system influence study*

The complete force lever system was redesigned: it was adapted to the final lever arm design, some parts were improved in order to reduce their weight and the housings for the selected force transducers were improved as well. Again, the same influences were studied, in order to check their overall effect on the system. The most relevant parameters under interest were the lever arm length variation (after being included in the complete system) and the force reaction in the force transducer (Figure 4).

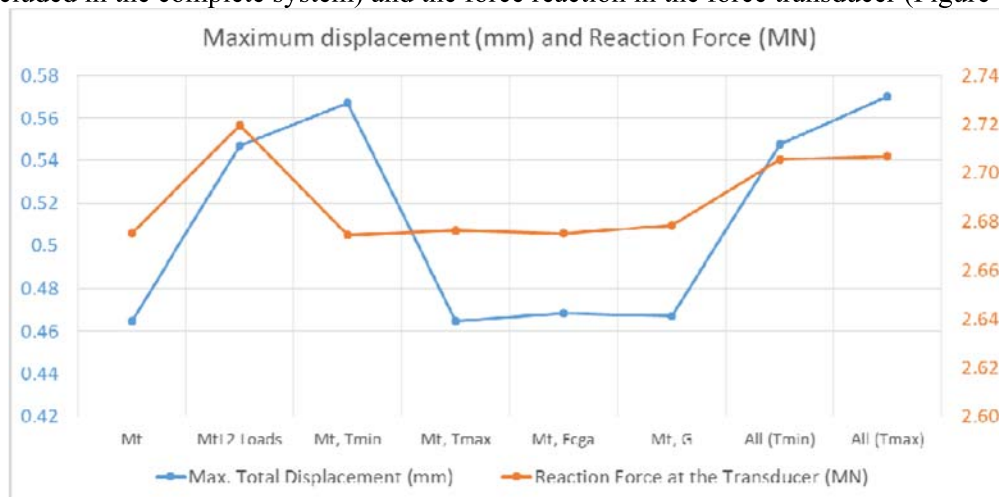

**Figure 4.** Maximum displacements and reaction force for the considered influences

Again, gravity and centrifugal force have a lower impact (both in the reaction force and lever arm displacement) than the other considered influences. Temperature effect has similar behaviour in the complete force lever system as it had on the former lever arm analysis: when studied separately, high temperatures have lower impact on the lever arm displacement than low temperatures (0.465 mm compared to 0.567 mm). However, when studying the combined effect, the lever arm deformation is bigger when suffering high temperatures (0.5703 mm), as the caused expansion has a similar direction to the deformation caused by the other loads.

Even considering the worst case scenario, with all the possible influences being applied, the deviation the theoretical lever arm length (607.5 mm) is quite low, with a variation lower than 0,1 % (Figure 5).

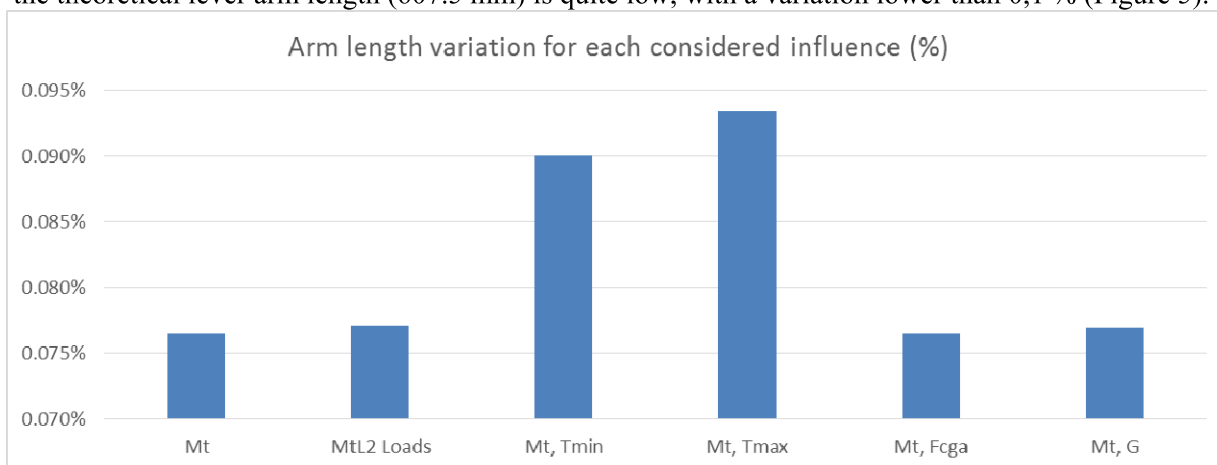

**Figure 5.** Deviation from the nominal lever arm radius (607.5 mm).

#### 4. Conclusions

An uncertainty budget estimation is being developed based on the FEM analyses results. The maximum variations of the force and distance values under each considered influence will be included as uncertainty contribution for the final torque measurement calculation and its associated relative uncertainty estimation. First results on this calculations within have proved that the proposed transfer standard is not only feasible, but also can provide accurate, traceable torque measurements.

Thanks to the force lever system, a better wind turbine diagnosis will be possible. Further investigations based on torque measurements may lead to more efficient wind power generation facilities on a long-term basis.

#### References

- [1] EURAMET 2015 Publishable Summary for 14IND14: Torque measurement in the MN•m range.
- [2] EWEA 2011 UpWind: “Design limits and solutions for very large wind turbines: A 20 MW turbine is feasible.
- [3] G. Foyer, S. Kock 2017 Measurement uncertainty evaluation of torque measurements in nacelle test benches *IMEKO*.
- [4] R. M. Lorente, M. N. Medina, M. A. Sáenz, M. A. Sebastián 2017 Torque traceability for nacelle’s test benches: a design proposal *IMEKO*.

#### Acknowledgments

The EMPIR initiative is co-funded by the European Union’s Horizon 2020 research and innovation programme and the EMPIR Participating States.